

KENT PERK
Chiller Cum Water Dispenser
with in-built RO Purifier



HOUSE of PURITY

**Instruction Handbook for
Installation, Operation and Maintenance.**



UF

TDS
CONTROLLER

RO



Kent Deta Hai
**Sabse
Shudh Paani**

Mineral RO™ TECHNOLOGY

Maintains essential minerals while reducing dissolved impurities with double purification

RO + UF + TDS Control

Reverse Osmosis Water Purifier & TDS Controller

Mineral RO™ © 2005 - 2012 KENT RO SYSTEMS LTD, the process & purifier is patented vide patent no. 199716.

KENT Perk's design is registered vide registration no. 219309



Welcome to KENT

Dear Customer,

Welcome to the world of KENT, the leading brand in water purification industry of India. With a KENT product you have all the reasons to smile, as at KENT we take pride in the quality and laboratory-tested performance of our products. Backed by cutting edge technology, each KENT product provides solution for attaining purity in the most convenient manner.

We are confident that your decision to own KENT Perk Chiller Cum Water Dispenser with in-built RO Purifier will go a long way in serving you with purer and mineral enriched drinking water, thus keeping you and your family in good health. We assure that you will be satisfied with its trouble-free performance and quality without any compromise.

This manual is an effort towards acquainting you with operation and maintenance of KENT Perk Chiller Cum Water Dispenser with in-built RO Purifier. Read this manual carefully prior to using the product for easy operation of the system and retain it for future reference. To enjoy the benefits of warranty, fill up the enclosed warranty card and send the installation report within 15 days of purchase. For further assistance, feel free to contact your nearest KENT dealer or branch.

Best Wishes

KENT RO SYSTEMS LTD.



KENT

Mineral RO™

Water Purifiers

HOUSE of PURITY

Table of Contents

1. KENT Technology- A Breakthrough in Water Purification	1
2. Salient Features of KENT Perk	1
3. Reverse Osmosis Process	2
4. Ultrafiltration Process	3
5. Auto-Flushing System	3
6. Refrigeration Process	3
7. Water Flow Diagram	4
8. Electrical Circuit Diagram	5
9. Automatic Operation	5
10. Items in the Box	5
11. TDS Adjustment	6
12. Installation Instructions	6
13. Maintenance	7
14. Caution	7
15. Troubleshooting	8
16. Technical Specifications	8

KENT Technology- A Breakthrough in Water Purification

Presenting the **KENT Perk Chiller Cum Water Dispenser** with in-built RO Purifier. It uses state-of-the-art technology to provide purer & healthier drinking water. The heart of KENT Perk is a RO membrane having capillaries as small as 0.0001 microns which reduces dissolved impurities (salts and heavy metals) as well as harmful micro-biological impurities (bacteria, viruses etc.) and also converts hard water to sweet and purer drinking water. It also incorporates a UF membrane which further ensures reduction of harmful micro-organisms. KENT Perk also allows the user to control Total Dissolved Solids (TDS) level of purified water. Along with hundred percent purified water, KENT Perk provides you access to normal as well as cold filtered water.

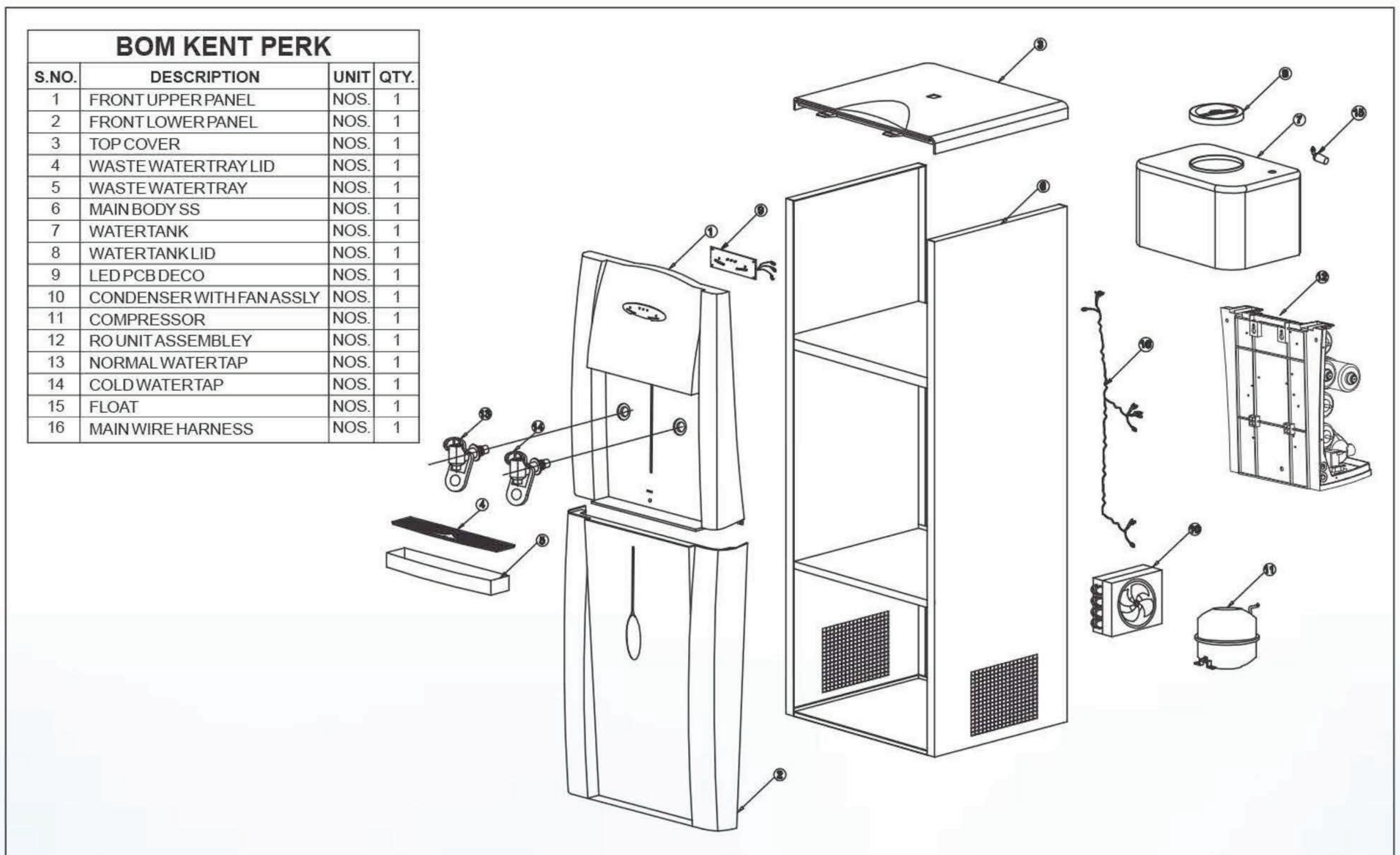

Salient Features of KENT Perk

KENT proudly presents **KENT Perk Chiller Cum Water Dispenser** with in-built RO Purifier – an advanced purer water dispenser based on a cutting edge technology which broadly comprises of RO+UF+TDS control systems, thus taking total care of your health and well-being. It has following features:

- **Multi-functional:** Supplies normal and cold water to fulfil your diversified needs i.e. making ice tea, cold beverages etc. It is a multi-functional machine for homes, offices, showrooms, institutions, hotels etc.
- **4-Stage Water Purification:** KENT Perk Chiller Cum Water Dispenser with in-built RO Purifier incorporates four stage water purification to ensure purer water. Moreover, it is ideal for municipal, corporation water supply.

- **Design:** KENT Perk has been aesthetically designed to fit in the work place as well as at residence
- **Ease of Access:** KENT Perk Chiller Cum Water Dispenser with in-built RO Purifier provides you an ease of connection to direct water supply, thus discarding need of mounting a bottle on the dispenser
- **Trouble-free Performance:** KENT Perk is easy to maintain and service. It has been rigorously tested under stringent conditions to ensure trouble-free service for years
- **Intelligent Controls:** Embedded with a refrigeration system, it utilises a double protection temperature controller which maintains the water temperature between 7-17°C. This range of temperature is ideal for making ice tea, lime water and other beverages
- **Secure Against Water Overflow:** KENT Perk Chiller Cum Water Dispenser with in-built RO Purifier integrates float valve which provides protection against water overflow

Reverse Osmosis Process

Reverse Osmosis, also known as hyper filtration, is one of the finest purification process known so far. It is a technique for purifying the water where pressure is applied to force liquid through a semi-permeable membrane as in the opposite direction of normal osmosis. This process reduces salts from potable or brackish water. When pressure is applied, purer water gets squeezed through the membrane from the concentrated side to the diluted side. Salts dissolved in water behave as charged ions and are repelled by the RO membrane. The rejected impurities on the concentrated side of the membrane are washed away by a stream of water, thus not accumulating, as they do in a traditional filter.

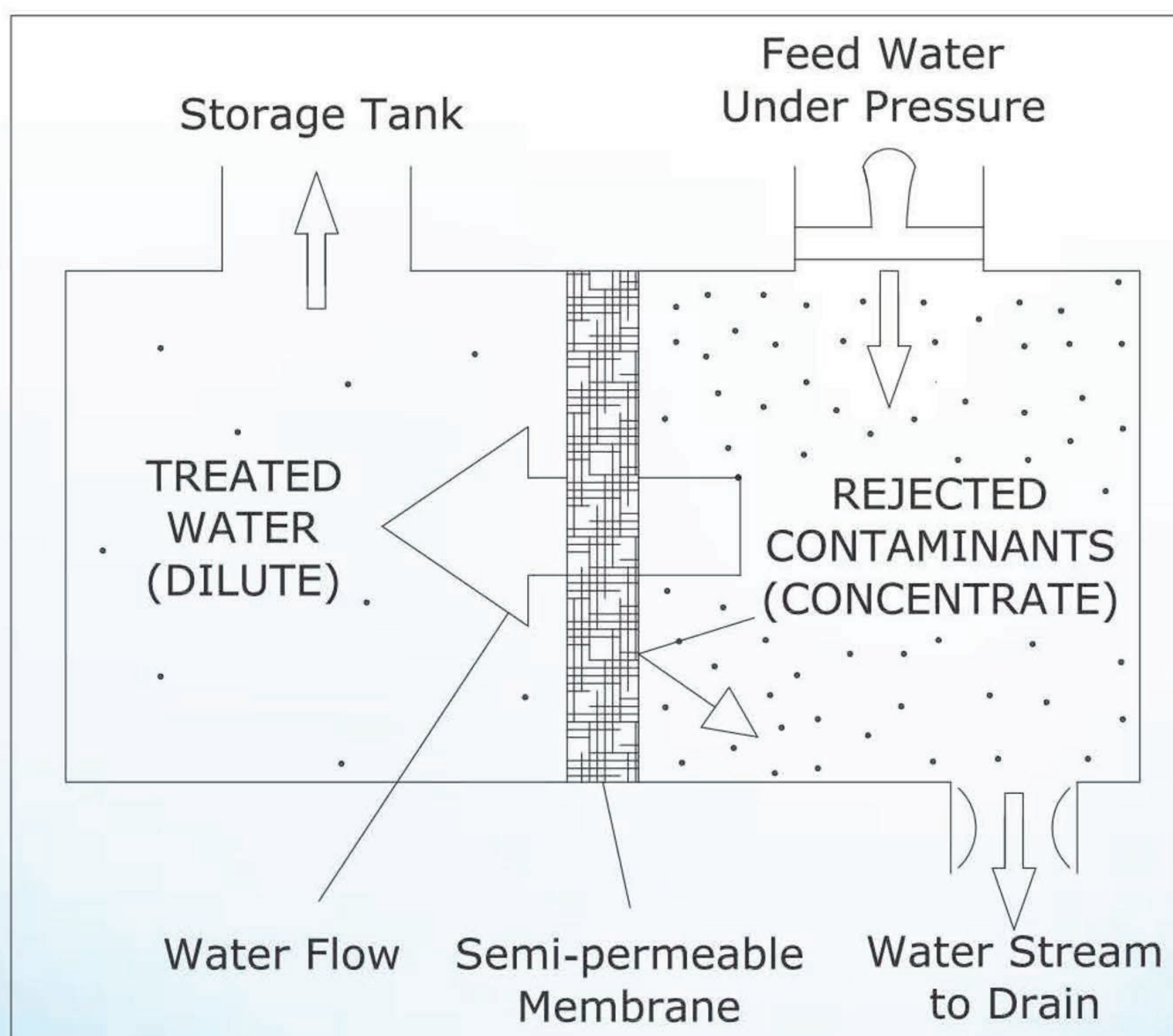

Ultrafiltration Process

Ultrafiltration is a technique for separating dissolved molecules in water on the basis of size which means that molecules larger than the membrane pore size rating will be retained at the surface of the membrane. It is a separation process that uses membrane with pore size of 0.01microns. UF membranes reduce high molecular weight substances, colloidal materials, organic and inorganic polymeric molecules along-with bacteria. Low applied pressures are therefore sufficient to achieve high flux rates from an ultrafiltration membrane.

Auto-Flushing System

The purpose of the Auto Flushing system is to help prevent scaling or fouling of the RO membrane by providing a rapid rinse which washes away impurities from the membrane's surface and keeps the membrane clean. It also offers the following benefits:

- Lowers reject water outflow
- Improves "TDS" rejection rate i.e.increases RO membrane efficiency
- Extends life of RO membrane.

Refrigeration Process

The refrigeration cycle is a common method for transferring heat from low temperature to high temperature. The four basic components of refrigeration cycle are:

- **Compressor:** The compressor serves two functions. It compresses the low-pressure, low-temperature gas into a high pressure, high-temperature gas and it keeps the refrigerant flowing through the cycle.
- **Condenser:** The condenser receives hot pressurised refrigerant gas from the compressor and cools it until the gas changes to a liquid state. In doing so, the condenser transfers heat from the refrigerant into the air surrounding the condenser coils.
- **Capillary Tube:** The capillary tube measures the amount of refrigerant released to the evaporator (coil type). They appear in the refrigeration cycle just before the evaporator (coil type). If the capillary tube is restricted, the proper flow of refrigerant will be disturbed and the water will not be adequately cooled.
- **Evaporator (Coil Type):** Refrigerant changes from liquid to gas in the evaporator and once again the refrigeration cycle begins.

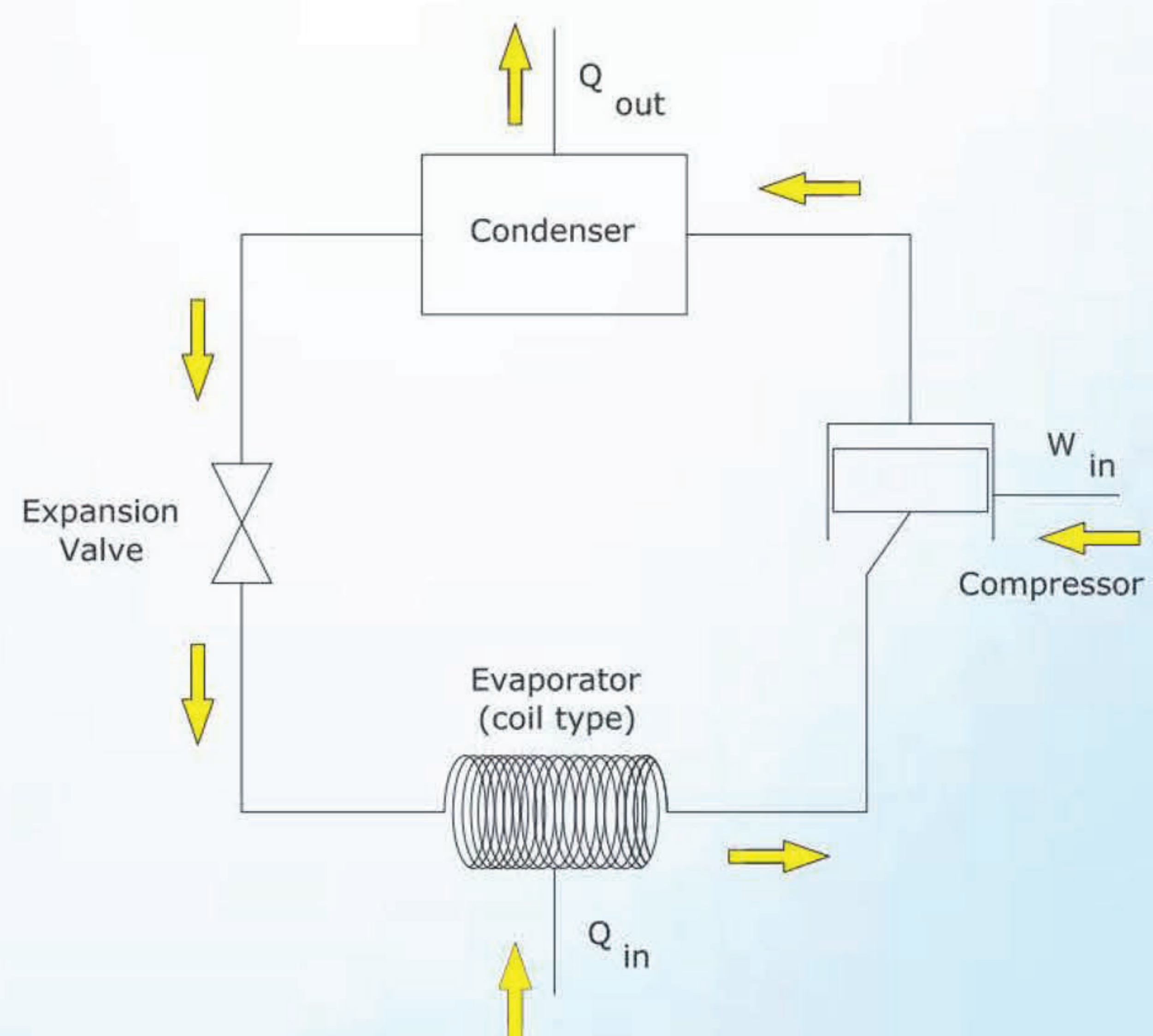

Water Flow Diagram

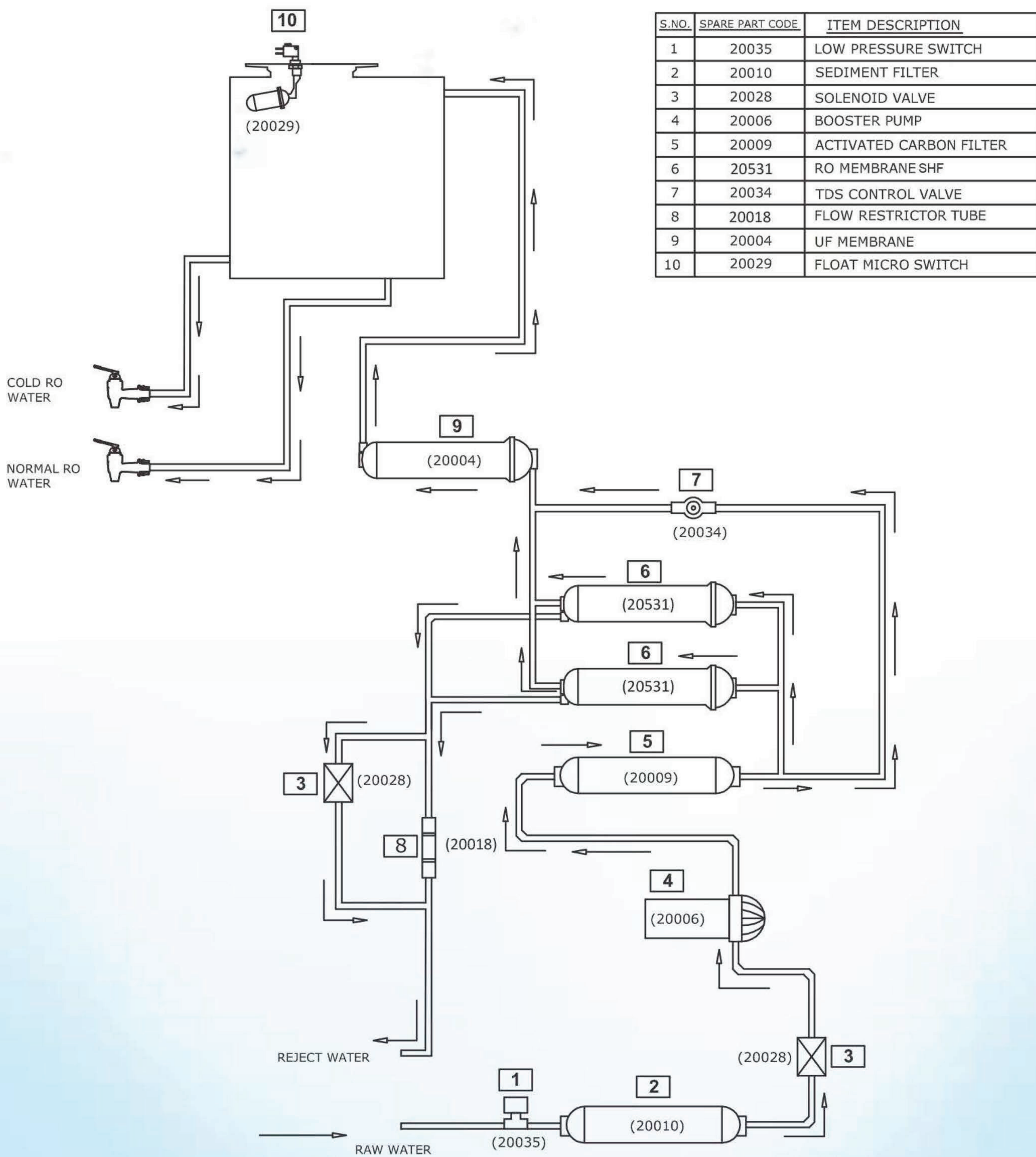

Water Flow Diagram

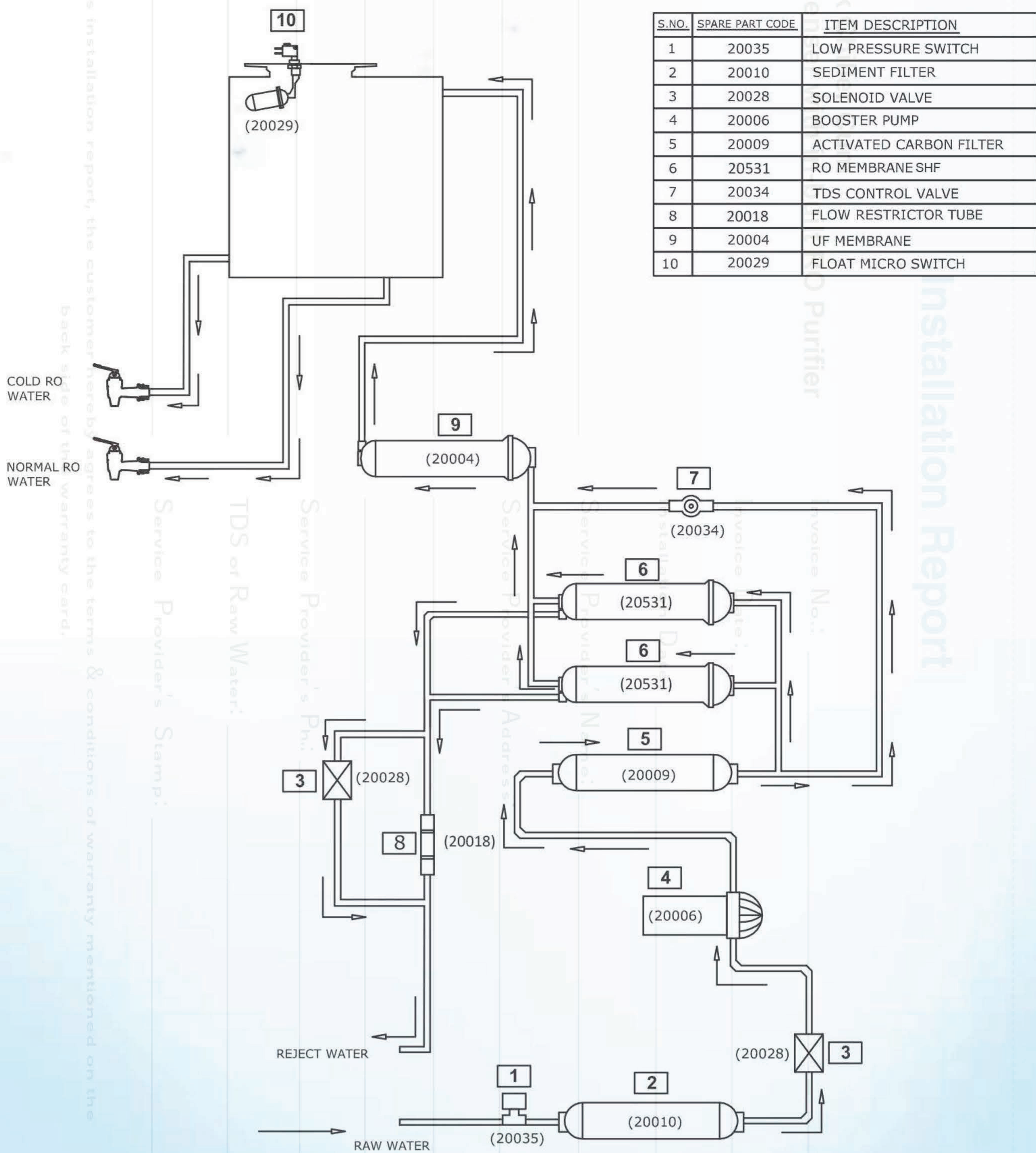

Electrical Circuit Diagram KENT Perk

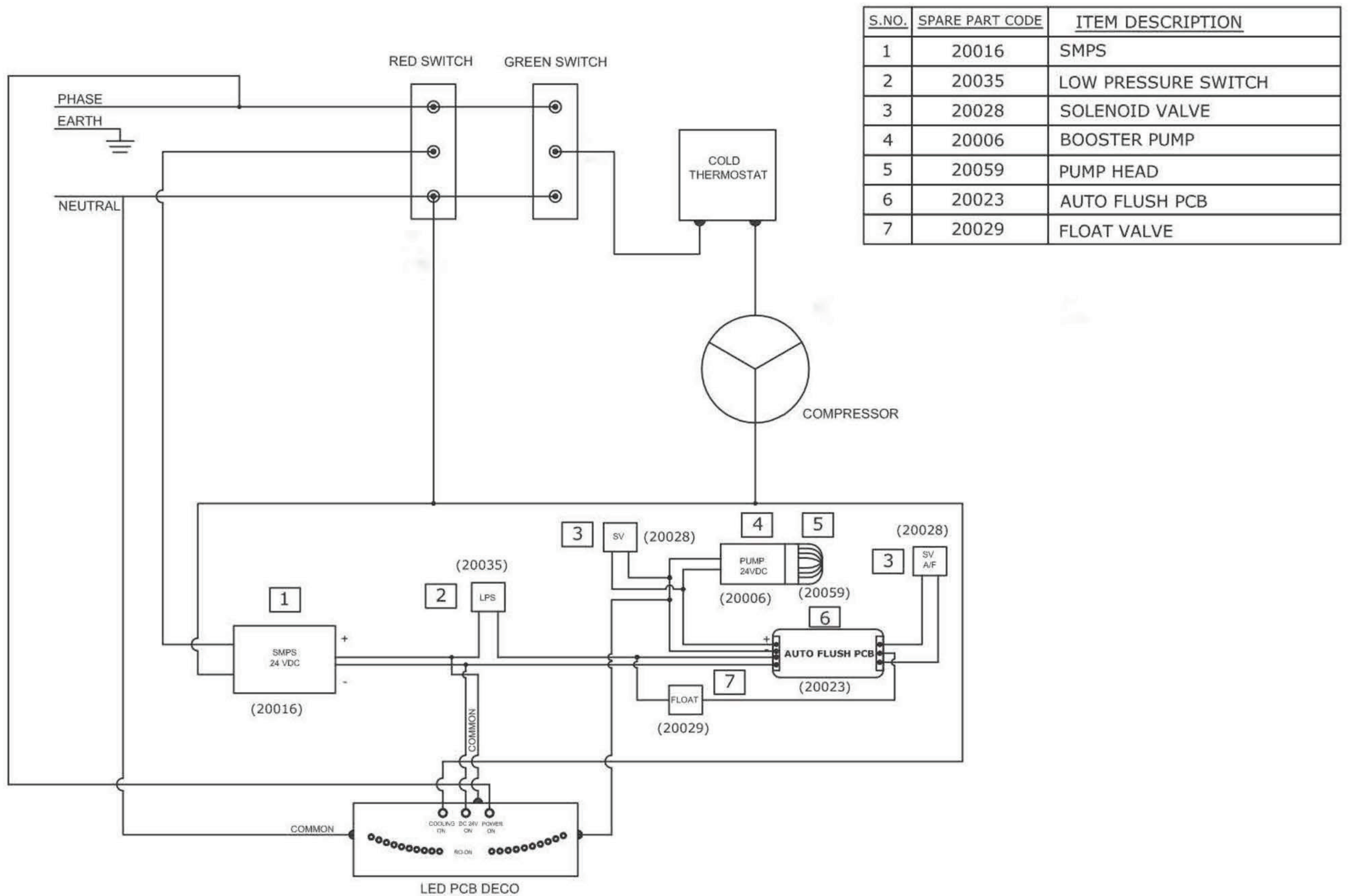

Automatic Operation

- Automatically shuts off water purification process when the storage tank is full
- Does not start water purification process when the inlet water supply pressure is below 0.3kg/cm^2
- Restarts water purification process when the water level drops below the maximum level
- Stops water purification process in the absence of electricity, thus ensuring that a user gets only purified water
- Resumes water purification process once the electrical supply is available
- Water cooling is ceased when temperature drops to 7°C

Items in the Box

- | | | |
|---------------------------------|---|-----------|
| 1. 3-Way Connector | : | 01 No. |
| 2. S.S. Ball Valve | : | 01 No. |
| 3. Food Grade Pipe 3/8" (White) | : | 03 Meters |
| 4. Food Grade Pipe 3/8" (Blue) | : | 03 Meters |
| 5. Instruction Manual | : | 01 No. |

TDS Adjustment*

The unique TDS control system enables customers to retain natural minerals in the purified water as per the requirement.

- To increase the TDS level (mineral contents), turn the screw of the valve anticlockwise
- To decrease the TDS level (mineral contents), turn the screw of the valve clockwise

*** Tested & Certified by TUV-SUD South Asia (P) Ltd.**

Installation Instructions

1. Unpack machine and place it on a levelled surface.

2. Fix the S.S. ball valve to the ¼ inch port of the 3-way connector as shown in the figure.



3. Connect the 3-way connector to the raw water supply as shown in the figure. The threaded end of the 3-way connector is fitted in line with the raw water supply. The other end can be connected to a tap or can be plugged off if not required.

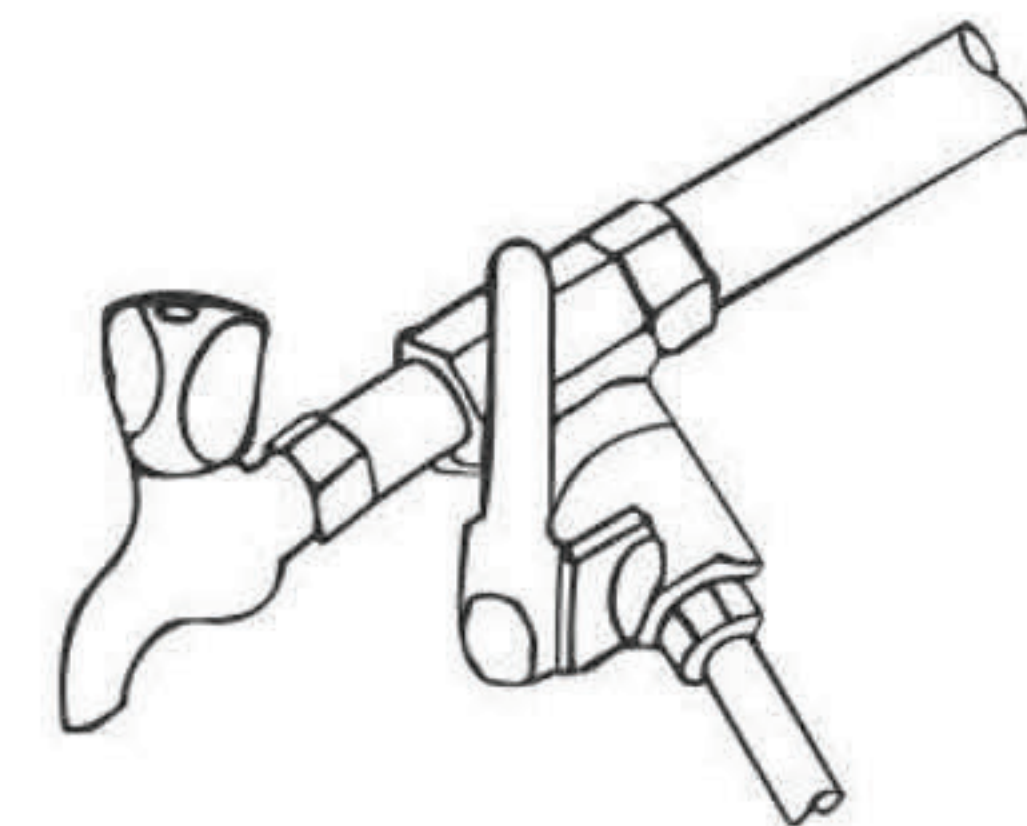

4. Now connect one end of the first fitting to the S.S. ball valve and other end to the lower pushfit fitting on the back side of the dispenser labelled as water in. (Note: White pipe is for raw water supply)



5. Similarly, connect one end of the blue pipe to the second fitting connector and leave the other end in the drain. (Note: Blue pipe is for reject water)

6. Before connecting the power supply, it is important that you perform the following functions:

- (I) Open the S.S. ball valve (handle parallel to the ball valve) to start the flow of water into the purifier.
- (II) Wait for 2-3 minutes to ensure that the filters are soaked in water.

7. Insert the power cord into the socket and then turn on the switches. Do not turn on the switches at the same time. The LED on the front panel then flashes to indicate that the system is ready to use (each LED light is having a different switch).

8. The system and installation needs to comply with state & local laws & regulations.

Maintenance

- Ensure to keep at least 15 cm of distance between the device & wall
- Keep the unit away from direct sunlight and rain
- Empty water tank before cleaning the device
- Unplug the machine and drain out the water by opening the tap if unused for a long period of time
- This appliance is not intended for use for persons with reduced physical, sensory or mental capabilities, or lack of experience and knowledge, unless they have been given supervision or instruction concerning use of the appliance by a person responsible for their safety. Children should be supervised to ensure that they do not play with the appliance

The reverse osmosis system contains a replaceable treatment component critical for the effective reduction of total dissolved solids and that product water shall be tested periodically to verify that the system is performing properly.

Replacement of spare parts are as under:-

-20010	SP Inline Sediment Filter 8"
-20009	SP Inline Carbon Block Filter 8"
-20531	SP RO Membrane SHF
-20004	SP Welded UF Membrane 8"
-20018	SP FRT 550/600

Note: Filters and membrane are consumables. Their replacement time is dependent on the quality of raw water and water consumption. They are not covered under the warranty. However, if a filter chokes within six months and a membrane within a year, it will be cleaned/repaired/replaced free of cost. Changing the filters and system inspection is available on call. The treatment capacity of RO membrane will reduce with time due to clogging of pores of membranes.

“This reverse osmosis system contains a replaceable component critical to the efficiency of the purifiers. Replacement of the reverse osmosis component should be with one of identical specifications as defined by the manufacturer, to ensure the same efficiency and contaminant reduction performance.”

Caution

- Make sure that the dispenser is connected to normal water supply only
- Make sure that the reject water pipe is not placed at a level higher from the dispenser, otherwise reject water may flow backwards into the purifier
- The maximum distance between the water source and the dispenser should not be more than 3 meters
- To keep the storage tank clean, it should be drained once in 15 days
- In case of not using the dispenser for more than two days, kindly switch off the power supply and drain the storage tank
- Do not try to service the dispenser on your own. Instead call service technician for help
- If the supply cord is damaged, it must be replaced by the manufacture, it's service agent or similarly qualified person in order to avoid hazard

Troubleshooting

No.	Breakdown	Reason
1.	No water output from machine	<ul style="list-style-type: none"> No inlet water supply Power cord not plugged properly
2.	Amplitude vibration and loud noise	<ul style="list-style-type: none"> The device has not been placed on an even surface
3.	Water overflow from tank	<ul style="list-style-type: none"> Float valve not working

Technical Specifications

PRODUCT	KENT Perk Chiller Cum Water Dispenser
Product Code	111010
Applications	Suitable for Brackish/Tap Water
Purification Capacity	Up to 40 L/hr.*
Body Material	ABS Food Grade Plastic
Installation	Floor Standing
Dimensions (mm)	L 425 X W 400 X H 1345
Inlet Water Pressure (Min.)	0.3kg/cm ² or 29419.95 Pa
Inlet Water Pressure (Max.)	3kg/cm ² or 294199.5 Pa
Filter Cartridge	Sediment, Carbon Filter
UF Filter	Ultrafiltration Membrane
Auto Flushing System	Yes
Storage Capacity	20L
Membrane Type	Thin Film Composite RO 1812-75GPD
Booster Pump Voltage	24VDC
Rated Current	1.8 Amp
Cooling Capacity (±5%)	755BTU/hr
Compressor	THK9384YCG, Tecumseh make or equivalent
Temp. Class	ST
Refrigerant	R134a
Refrigerant Mass	90g
Condenser	Forced convection air cooled
Condenser Fan	Axial Flow Type
Expansion Device	Capillary Tube
Evaporator	Coil Type
Weight	38.0kg
Input Power Supply	230 V AC, 50/60 Hz 

* Treatment capacity tested for tap water having TDS level of 750 ppm at room temperature.

“Do not use with water that is microbiologically unsafe or of unknown quality w/o adequate disinfection before or after the system.

“Efficiency rating means the percentage of the influent water that is available to the user as reverse osmosis treated water under operating condition that approximate typical daily usage.”



HOUSE of PURITY



8 906019 940370

SERVICE

For Prompt Installation & Service
Call from anywhere in India at

092-789-12345
(All days 8am to 8pm)

KENT
Mineral RO
Water Purifiers

Service complaints can also be lodged on KENT SERVICE MOBILE APP for android phone (Download by giving a missed call at 9212252852)



Marketed by:
KENT RO SYSTEMS LTD.
E-6, 7 & 8, Sector-59, Noida, U.P.-201 309, India.
Ph.: +91-120-3075000
E-mail: sales@kent.co.in Website: www.kent.co.in

Manufactured by:
KENT RO SYSTEMS LTD.
Khasra No. 93, Village-Bantakhedi, Tehsil-Roorkee,
District-Haridwar, Uttarakhand-247 668, India.

For customer complaints, contact our Customer Care Officer at:
E-6, 7 & 8, Sector -59, Noida, U.P. - 201 309, India. Call: 092-789-12345
E-mail: service@kent.co.in or visit us at www.kent.co.in